





GENUINE SIDE UNDER SKIRT

INSTALLATION AND USER'S INSTRUCTIONS

Thank you for purchasing a genuine Mazda accessory.
Before removal and installation, be sure to thoroughly read these instructions.
Please read the contents of this booklet in order to properly install and use the side under skirt. Your safety depends on it.
Keep these instructions with your vehicle records for future reference.

WARNING

- There are several  **WARNING** and  **CAUTION** sections in this booklet concerning safety when installing or removing the side under skirt. Always read and follow them in order to prevent injuries, accidents, and possible damage to the vehicle.
 -  **WARNING:** Indicates a situation in which serious injury or death could result if the warning is ignored.
 -  **CAUTION:** Indicates a situation in which bodily injury or damage to the vehicle could result if the caution is ignored.
- For areas indicating the tightening torque in this instruction manual, tighten to the specified torque using a torque wrench. For areas in which the tightening torque is indicated inside parentheses (), the tightening torque is indicated as a reference value, however tightening using a torque wrench is not necessary.
- Do not modify the side under skirt.
- Do not install the side under skirt. In any way other than described in the following instructions.
- If in any doubt, please ask your Mazda dealer to install the accessory in order to prevent errors in installation.
- If you have any questions about the use of the accessory, ask your Mazda dealer for proper advice before using it.
- Mazda and its suppliers are not responsible for injuries, accidents, and damage to persons and property that arise from the failure of the dealer or installer to follow these instructions.
- To ensure safety and reliability of the work, installation, removal and disposal work must be carried out by an Authorized Mazda Dealership.
- Be careful not to lose removed parts and be sure that they are kept free from scratches, grease or other dirt.

PART NAME: SIDE UNDER SKIRT
PART NUMBER: QBMN 51 P10
QBME 51 P10
QBMR 51 P10
VEHICLE: MAZDA3

NOTE

To the dealer

- Please turn over these instructions to the customer after installation.

To the customer

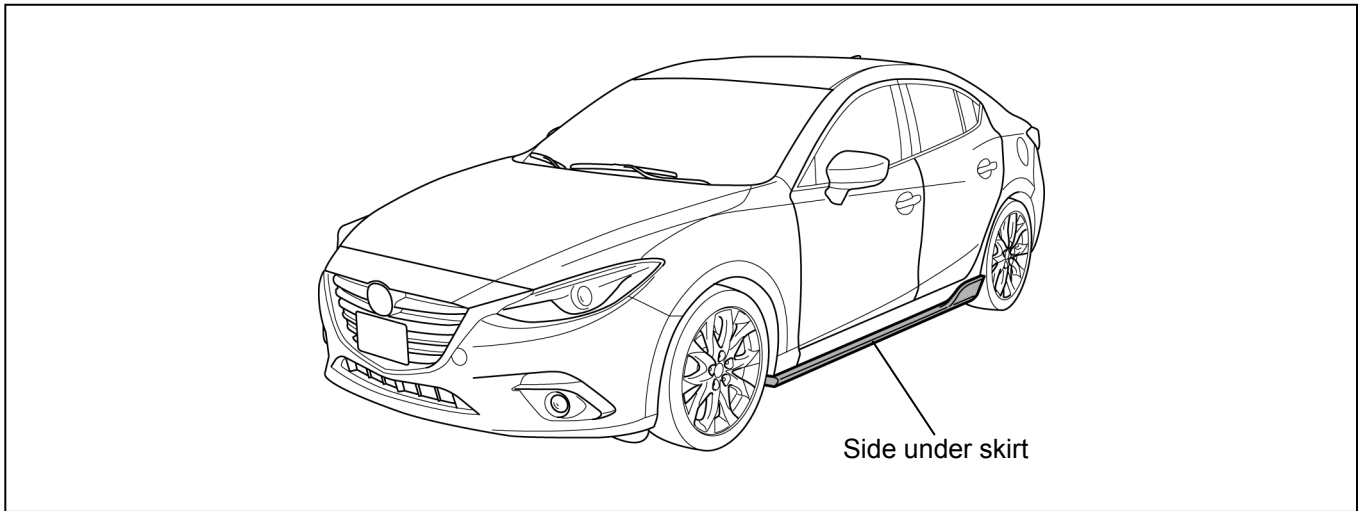

- Keep these instructions after installation. The instructions may be necessary for installing other optional parts or removal of this accessory.
- Should the vehicle or this accessory be resold, always leave these instructions with it for the next owner.

1. INSTALLATION VIEW



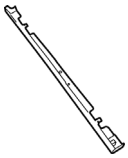
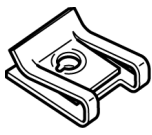

2. PARTS

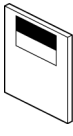
- Before installation, verify that the kit includes all the following parts and that they are free of dirt, scratches, or damage.

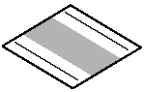
Part	Part name	Qty	Part	Part name	Qty
	Side under skirt	2		Clip nut	2
	Screw	2		Installation and user's Instructions (Three languages: English, French and spanish)	1ea.

Sold separately	Part name	Qty
	Primer (3M Promoter 4298)	1

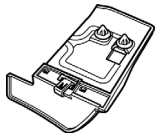
For vehicles with stone guard only (BHR1 V4 919)

Sold separately	Part name	Qty	Part	Part name	Qty
	Deflector	2		Hole cover (large)	12

3. BEFORE INSTALLATION

■ REQUIRED TOOLS

- ☆Screwdriver (Phillips) (stubby type)
- ☆Fastener remover
- ☆Soft, clean cloth
- ☆Isopropyl alcohol (IPA)

⚠ WARNING

Park the vehicle on a flat, level surface, set the selector lever to P (AT vehicles) or the shift lever to 1st or R (MT vehicles), apply the parking brake and block the wheels so that the vehicle does not move during installation.

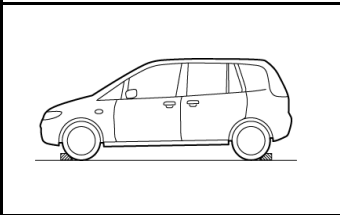

⚠ CAUTION

<p>Be sure to cover the vehicle body with protectors or mats to prevent stains, scratches and damage when removing/installing the vehicle parts</p>	<p>Using improper tools may cause damage and or broken parts. Use the correct tool for the job.</p>	<p>Put the removed parts and the parts in the kit on a protective sheet to prevent scratches.</p>	<p>Put the removed parts and the parts in the kit on a protective sheet to prevent scratches.</p>

If there's dust, dirt or grease on the surface of adherend, the surface of two-sided tape will splotch and adhesive power of the tape will be reduced. It is required to wash the surface of the adherend before adhesion. Be sure to wash interior and exterior parts using IPA (isopropyl alcohol).

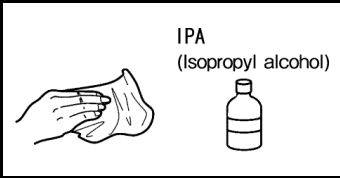

Advice

Refer to the Workshop Manual for removal and installation of vehicle parts.



4. SIDE UNDER SKIRT INSTALLATION

- The figures show the right side, however, the procedure for the right side is the same.

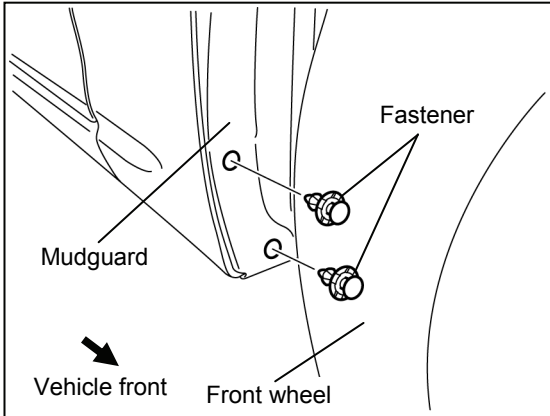

1. Remove the fasteners (2) shown in the figure.

- The removed upper fastener is reused.
- The removed lower fastener is not reused.

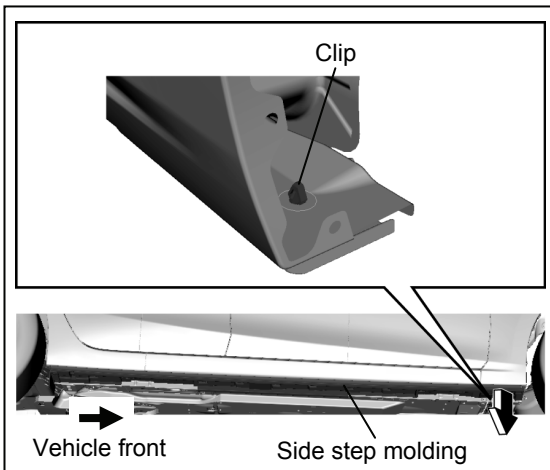

- For vehicles with stone guard : Go to part "2"
- For vehicles without stone guard : Go to part "10"

- **For vehicles with stone guard only**
[For European models only]

2. Move the side step molding in the direction of arrow shown in the figure and remove clip from the body while pinching clip using pliers.

- The removed clip is not reused.

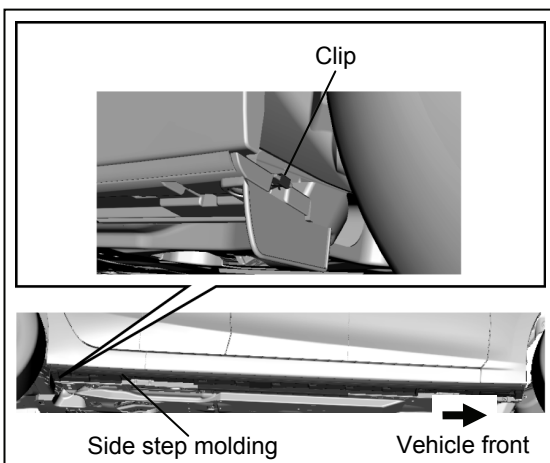

3. Remove the clip shown in the figure.

- The removed clip is not reused.

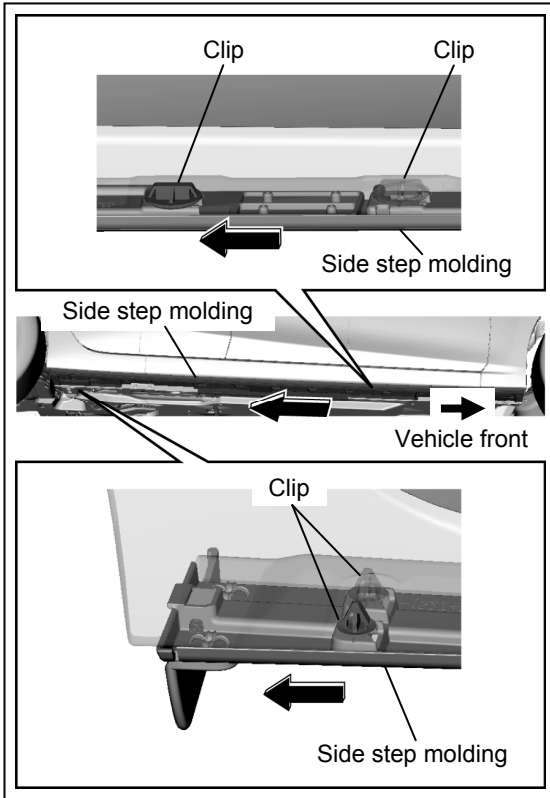

4. Move the side step molding in the direction of the arrow, and remove the side step molding.

- The removed side step molding is not reused.

5. After removing the side step molding, remove clips from the body using a fastener remover.

- The removed clip is not reused.

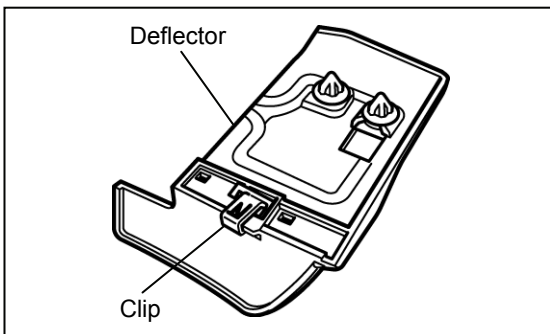

6. Remove the clip from the deflector sold separately in a mounting kit.

- Store the removed clip so that it does not become lost.

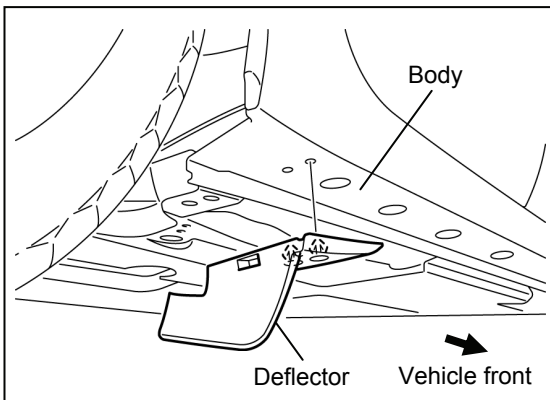

7. Install the deflector to the body.

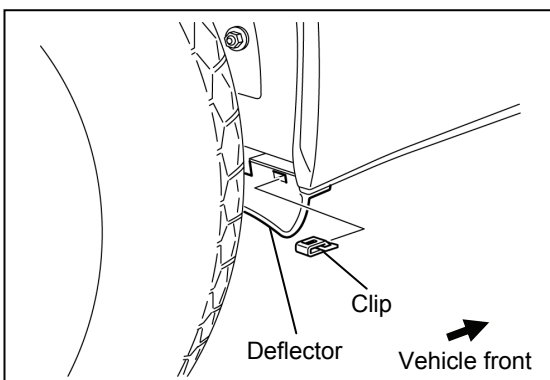

8. Secure the deflector using the clip.

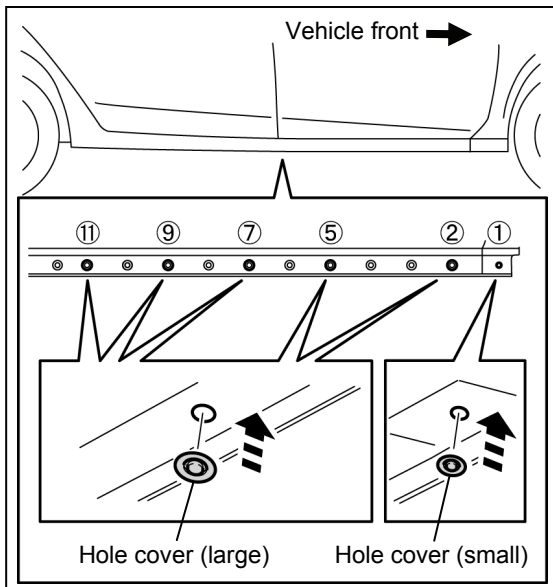

9. Install the hole covers (large) to the bottom surface of the side sill panel shown in the figure (2nd, 5th, 7th, 9th, and 11th holes from the vehicle front).

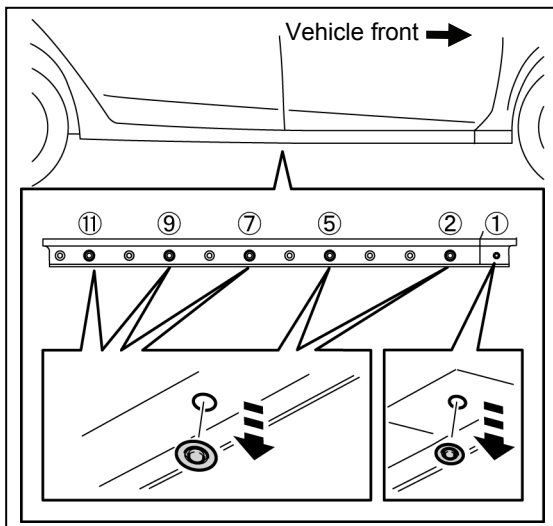

■ **For vehicles without stone guard only**

10. Remove the hole covers on the bottom surface of the side sill panel shown in the figure (1st, 2nd, 5th, 7th, 9th, and 11th ones from vehicle front).

- The removed hole covers are not reused.

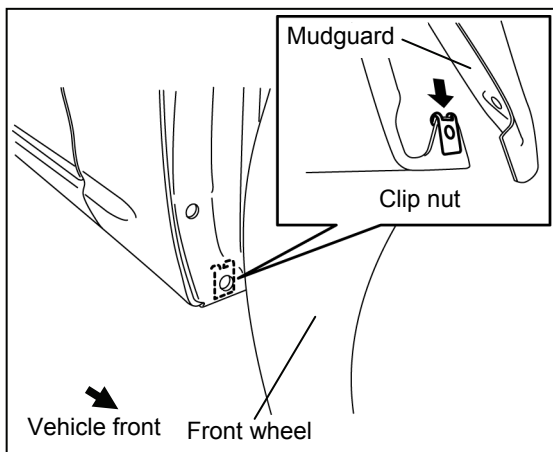

■ **For all vehicles**

11. Partially peel back the mudguard, then align the clip nut to the installation hole on the front fender and install it.

— **ADVICE** —

- Install the clip nut with its flat side facing frontwards. If it is installed facing backwards, the mudguard cannot be returned to its original position.

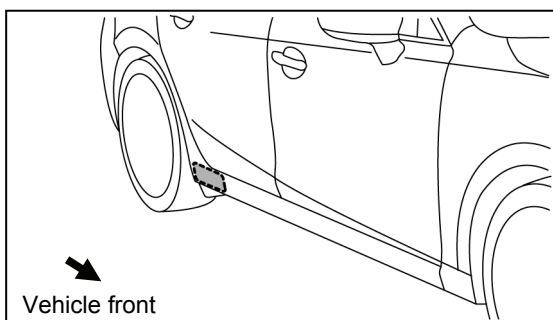

12. Wipe the double-sided adhesive tape adhesion surface using IPA (isopropyl alcohol).

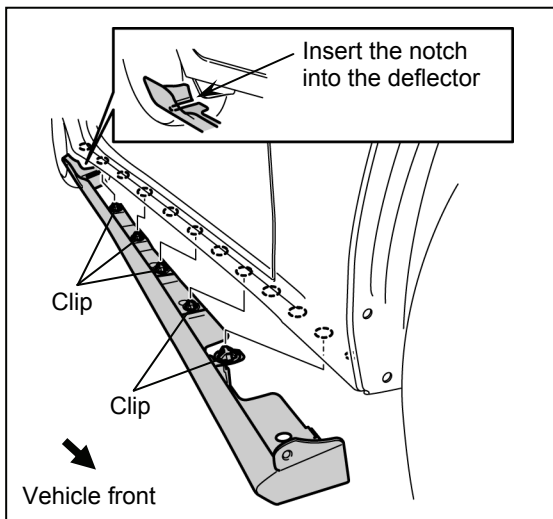

13. Insert the clips starting from the front to the rear of the side under skirt.

ADVICE

- Press the clips in gently. If the clips are pressed in with excessive force, they will deform and it may become difficult to insert them.
- Install it while being careful of the alignment with the vehicle.

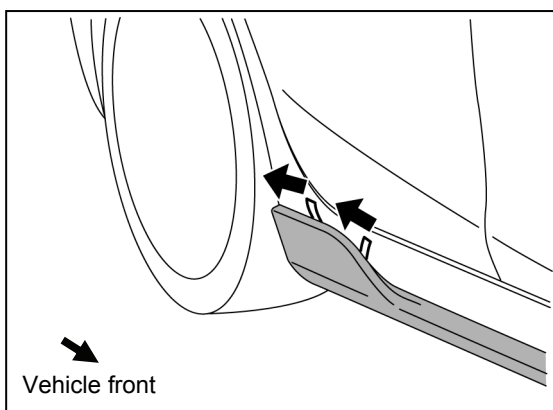

14. Remove the double-sided adhesive tape backings in the direction shown by the arrows, and press the tape sufficiently to affix it to the body.

ADVICE

- To prevent loss of adhesive strength, do not remove the rear side skirt once it has been affixed.
- Do not wash the vehicle for 24 hours after installation.
- If the sealant causes interference, cut off the sealant where it interferences.

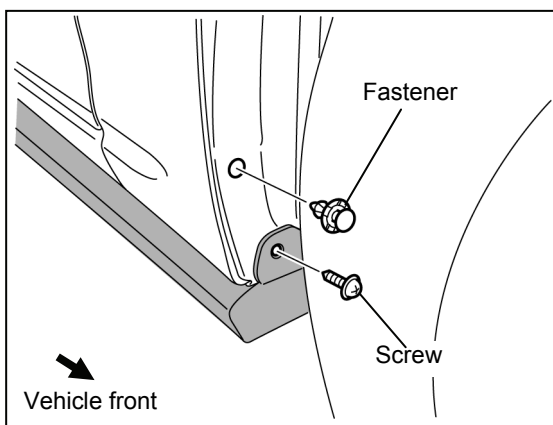

15. Install the fastener and the screw.

Screw tightening torque:(0.8—1.2 N·m)

5. INSPECTION ITEMS AFTER INSTALLATION

1. Make sure that there are no gaps.

- If there are any gaps, loosen the screw, and retighten it while pressing the side under skirt against the mudguard.

2. Inspect the installation of the installed screws.

6. TO THE CUSTOMER

Please pay attention to the following with regard to handling (maintenance) of the side under skirt.

- If the hard plastic parts come into contact with gasoline, oil, refrigerant, or battery fluid, it could cause discoloration, staining or damage. Use a soft, clean cloth to wipe such fluids off immediately.
- Depending on the type of high pressure car washer used, the water for washing may be high temperature and/or under high pressure. Be careful when using pressurized water from a car washer nozzle. If the nozzle is too close or water pressure is applied for long periods, it may cause deformation or damage to the hard plastic parts.
- Do not use electric or air tools to apply wax or compound (polishing powder). Otherwise, friction heat will be generated causing deformation or damage to the hard plastic parts.
- If the vehicle height is lowered due to the vehicle being at maximum passenger or cargo capacity, decrease the vehicle speed when parking on a road shoulder or entering/leaving a road shoulder or bump. Otherwise, the side under skirt could be damaged.

Date _____ , _____ , _____				
VIN _____				
Approved		Checked		Person in charge

INSTALLATION INSPECTION SHEET	MAZDA3	Side under skirt
		QBMN 51 P10 QBME 51 P10 QBMR 51 P10

Perform the following inspections

Inspection items after installation

Check

- Verify the fitting between the vehicle part and the installed part, and inspect for damage or dirt.